

AICON PIPE XR-4.0"

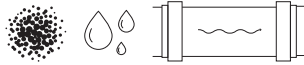

A modern X-ray inspection system designed to control the quality of liquid, semi-liquid and fragmented products transported by a 4.0" pipe. This device provides the highest available level of contamination detection while minimizing the rejection of uncontaminated product. The robust construction of the AICON PIPE XR device – made to the IP69 standard – allows operation to continue even under the most demanding production conditions.



150 m/min
Speed



10 Gb/s
Processing



10 m³/h
Performance

ADVANTAGES

- **Effective detection** - the highest detection level (POD) of metallic contamination, glass, stones, calcified bones, Teflon, ceramics, dense plastics, product lumps and more, with the lowest false rejection rate (FRR).
- **Multifunctional** - thanks to the industry-record number of image analysis algorithms, AICON X-RAY detectors can efficiently handle any type of application.
- **High-performance** - innovative data processing method supporting production lines of up to 10 m³/h.
- **Dual Energy Imaging** - the optional Dual Energy Imaging technology uses two different radiation energies to differentiate between materials in order to more precisely detect contaminants in products that are "difficult" or inhomogeneous in terms of X-ray detection technology (for example, products that have different density, random arrangement or overlap).
- **Convenient operation (Ease of use)** - intuitive operation thanks to the high ergonomics of the system and the automation of product learning.
- **Simple integration** - the turn-key solution enables uncomplicated and quick integration into the production environment.
- **Traceable** - full product history (including the manufacturing process) and easy access to a detailed archive data for quality control.

ADVANCED X-RAY INSPECTION SYSTEM FOR QUALITY CONTROL OF PRODUCTS TRANSPORTED IN PIPELINES

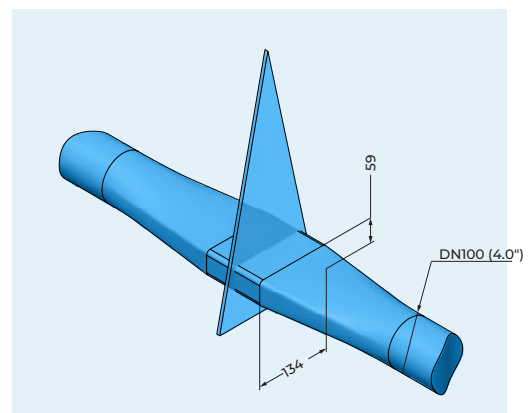

Beam geometry

TECHNOLOGY

- **High-efficiency, multi-threaded data processing** - the industry's highest multi-threaded data processing speeds - up to 10 Gb/s - for the most efficient image processing and maximum performance of the entire inspection system.
- **Self-control system** - AICON PIPE XR series devices are equipped with advanced built-in self-control system. This system guarantees stable operation of software and hardware, based on dual communication and redundant data processing. Devices built according to this concept perform continuous self-control in order to capture their own malfunctions at all stages of the product scanning process, from image creation to image analysis, through to reject of non-compliant product and the supervision of data acquisition.
- **Inverted inspection logic** - by default, AICON X-Ray devices treat every inspected product as non-compliant and therefore deemed to be rejected. It is only during the scanning process that the system analyses and determines whether the product meets the expected quality requirements, and whether its status can be changed to compliant. This inverted product inspection logic system greatly minimizes the risk of non-compliant products making it to market, even in the event of failure of any component in the inspection system.
- **Advanced tracking system** - comprehensive product flow control is performed in real time, ensuring precise tracking and reliable registration of the position of each product transported - regardless of line throughput or complexity of the production process.

FEATURES

- **An intelligent, ergonomic design** - ergonomic solutions ensure comfortable operation and allow for easy and quick system adjustment, should you need to replace individual consumable components. Plus, these systems have been designed to the highest standard of hygiene for easy maintenance regardless of manufacturing conditions.
- **Simple and easy to use** - simple and convenient operation, thanks to the highly ergonomic system and automated product learning.
- **Interface personalization** - flexibility to adjust the control panel to suit individual user requirements, allowing for higher operational comfort.
- **Full MES integration** - intelligent integration into the production environment and vast compatibility with current industry standards guarantee seamless communication of the X-ray detection system with key devices in the production line (including EtherNet/IP, PROFINET, S7, EtherCAT, Modbus-TCP, Profibus, CAN, CANopen, OPC UA, SQL, Siemens Standard and RS).

See more
on our website



TECHNICAL SPECIFICATION

AICON PIPE XR-4.0"

Troughput	10 m ³ /h
Detection area	4.0"
Diode resolution	0,2 mm – 0,8 mm, Dual Energy
X-ray source	35-100 kV / 1.0-8.0 mA, 500 W
Number of scanning beams	1
Beam direction	Vertical
X-ray emission	<1 µSv / h, the product complies with legal EU directives
Cooling	Dry Air Cooling system
Operating environment	Temperature: 0 - 45 ° C, humidity: 30 - 95%, non-condensing
Ingress Protection	IP65 (optional IP69)
Construction material	Bead-blasted stainless steel 1.4301 (AISI 304)
Display	TFT LCD 15" Touchscreen
Operating system	Windows 10 Enterprise
Software	AiSoft
Number of product programmes	1000
Disk space	500 GB for x-ray pictures and internal data storage, expandable
Communication interfaces	Ethernet 10/100/1000 mbps, USB 3.0 for external data storage
Air requirement	Min. 6 bar for pneumatic rejection systems
Power supply	Single phase, 230 VAC +/-10%, fuse 16 A
Dimensions	2163 mm x 1022 mm x 2277 mm (L x B x H)

